



Solvex™ Expander

Designed to improve the efficiency of
oil recovery in solvent extraction



ANDERSON
INTERNATIONAL CORP



Raw flakes enter:

20-25 pounds/cubic foot
0.32-0.40 grams/cubic centimeter
0.016-0.020" thick
0.4-0.5mm thick
10-11% moisture
60°C (140°F)

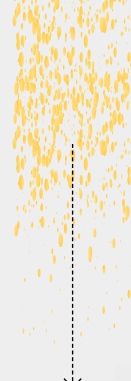

Feed Conveyor

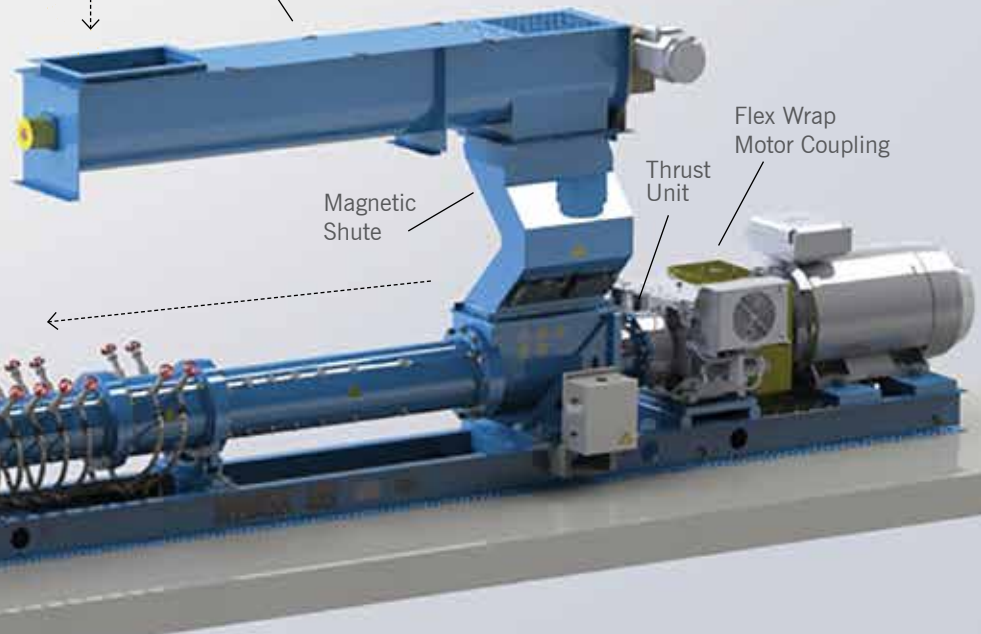

Flex Wrap Motor Coupling

Thrust Unit

Magnetic Shute

Steam is injected in barrel

Dual Choke



Cooler with air flow

(cyclone not shown)

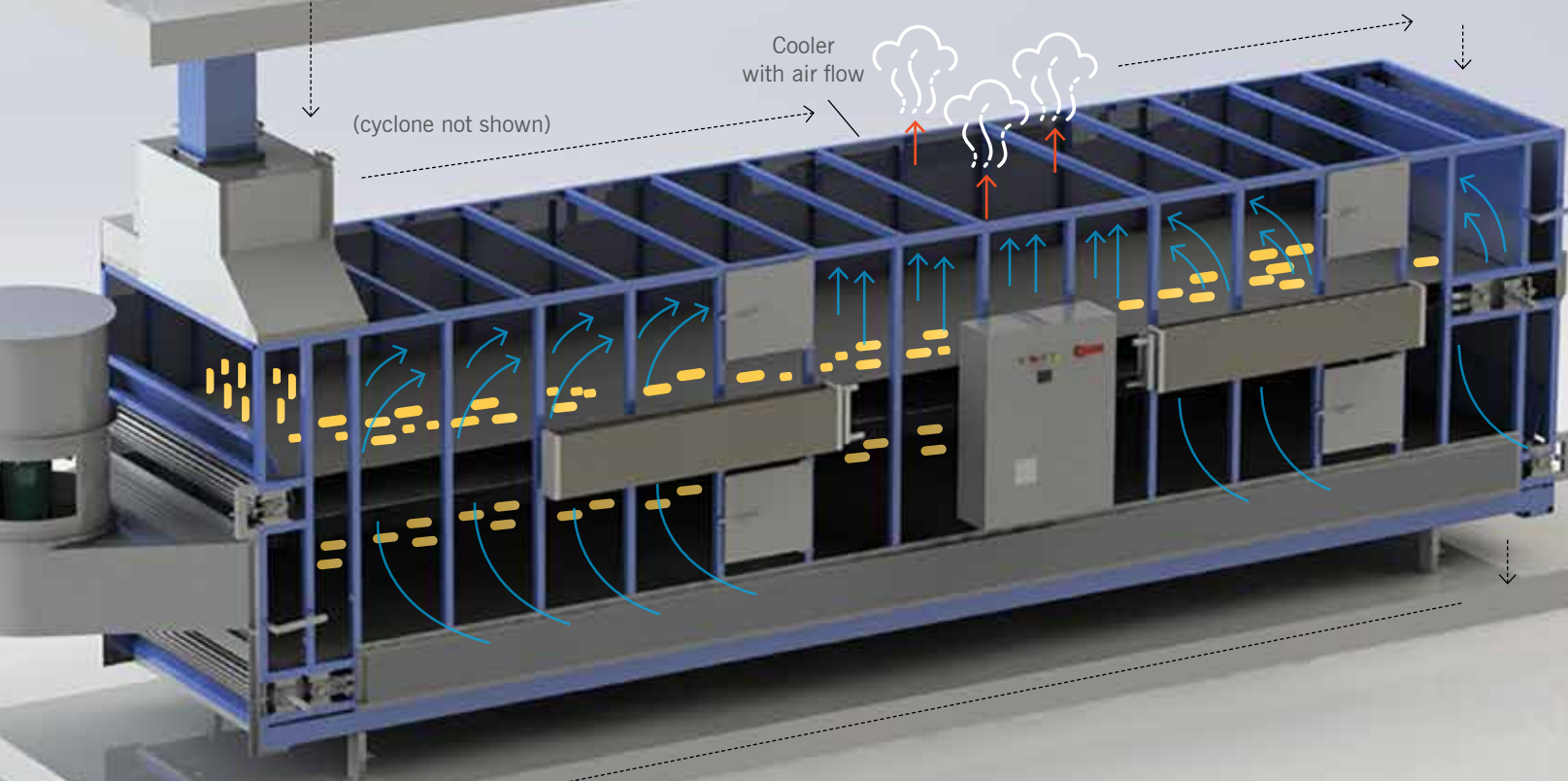

Finished collet:

35 pounds/cubic foot
0.56 grams/cubic centimeter
60°C (140°F)





Anderson Solvex™ Expander

The Anderson Solvex packs material to be extracted into a dense, yet very porous structure. This allows the solvent easier access to the oil, resulting in up to 50% increases in extractor capacity, 40% reduction in solvent hold-up in the solid product (marc), 20% reduction in solvent in the liquid product (miscella), and an overall reduction in solvent losses.

Expanders, like the Solvex, lower overall plant energy consumption and loading on the extractor, hence reducing their operational costs and increasing their capacity. The Solvex can also reform dense pre-press cake into a porous collet for improved extractor efficiency on high oil content materials, providing similar benefits as with soybeans.

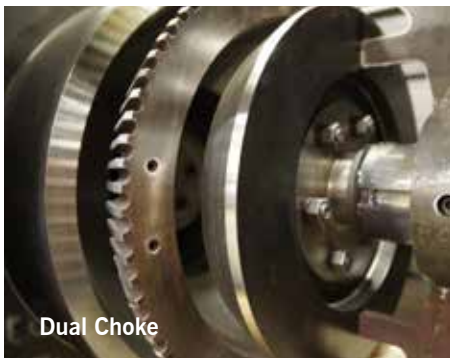

Dual Choke



Flex Wrap Motor Coupling

Applications

- Soybeans
- Cottonseed
- Rice-bran
- Sunflower
- Canola/Rapeseed
- Pre-Pressed Cake

Benefits

- Up to 50% increase in extractor capacity
- Residual oil levels as low as 0.6%
- Reduction in fines
- Higher extractor percolation rates
- Lower solvent to meal Ratios
- Higher miscella concentration
- Lower steam consumption
- Lower solvent loss
- Reduction in non-hydratable phospholipid content

Model	Connected HP	Capacity (MTPD)	Steam (150 psi)
8" Solvex	125-200	200-400	500-1,000 lbs/hr (225-450 kg/hr)
10" Solvex	150-250	500-800	1,250-2,000 lbs/hr (560-900 kg/hr)
12" Solvex	300-500	1,200-1,800	3,000-4,500 lbs/hr (1,350-2,050 kg/hr)
14" Solvex	500-750	2,000-3,000	5,000-7,500 lbs/hr (2,250-3,400 kg/hr)

How an Expander Maximizes Oil Recovery in Solvent Extraction

The solvent extraction of soybean oil has become the most popular extraction method used across the globe. With a distinct advantage over traditional mechanical pressing, solvent extraction yields higher oil recovery and greater efficiency, leaving less than 1% residual oil in the meal.

Like all oilseed processors, plant operators using solvent extraction strive for efficiency and profitability. Yet, some operators overlook a critical step in their soybean oil extraction process to save significant time and energy.

Solvent extraction

In solvent extraction, flaked soybeans are washed with hot solvent, typically hexane, to separate the solids from the fats. Multiple washes dissolve the oil and carry it away. This oil solvent combination is also known as the miscella. The remaining material is the wet meal and solvent, also known as the marc. The marc and miscella are then subjected to heat treatment to remove the hexane and leave the finished products.

An extractor's efficiency, the number of solvent washes needed, and the amount of hexane used can vary significantly between machines. The use of an expander, like the Anderson Solvex™, can provide several critical benefits to increase solvent extraction efficiency.

How it works

Much like the Dox Extruder does for an expeller, the Solvex expander prepares the oilseed for an extractor. Both machines use heat for cooking the oilseed. However, unlike the Dox, which uses friction to generate heat, the Solvex uses steam as its primary heat source. Using steam generated heat, the screw propelling the material through the expander requires less horsepower per ton, allowing operators to process more material in a given timeframe.

The material exits the expander at the discharge openings under extreme pressure. As the material hits atmospheric conditions, the injected moisture suddenly expands to steam and explodes outwards, creating a network of pores in the soybean. As the heat escapes and vaporizes off, the material cools, solidifies, and gets harder – transforming the material into what processors refer to as soybean collets.

This new structure of porous, dense, large collets replaces the flaked soybeans that would otherwise be entering the extractor, resulting in a series of benefits.

High quality collets vs poor collets



strong, dense, high-quality collet



weak, low-quality collet

The benefits of using an expander to prepare oilseeds for extraction:

Increased capacity

The expander compresses the material, which allows for more capacity in the extractor. Specifically, the Solvex allows the extractor to accept 50% more soybean without any change in bed depth or residence time in the extractor. More capacity means reduced energy consumption and decreased operational costs.

Reduced solvent exposure

The large, porous collets, as opposed to the flakes, allow the solvent to flow faster and dissolve the fat more quickly. The hexane drains more effectively and reduces the amount of solvent required during extraction, saving processors from costly increases in solvent expenses.

Reduced solvent recovery

The solvent must be removed from both the marc and miscella to complete processing. Less solvent during washing means less heat is required downstream to remove the solvent. Specifically, Anderson's Solvex reduces the amount of solvent for recovery by 40% in the marc and 20% in the miscella.

Transform poor quality flakes

The expander can transform low-quality flakes into easily extracted collets, allowing operators to decrease the demands on flaking rolls. The rolls can run at a higher capacity, consume less horsepower per ton, and require less maintenance.

Re-form pre-press cakes

An expander can re-form dense pre-press cake into a porous collet for improved extractor efficiency on high oil content materials, providing similar benefits as with soybeans.



ANDERSON
INTERNATIONAL CORP

Anderson International invented the expander in 1966, paving the way in the industry for better efficiency in solvent extraction. The Anderson Solvex has a long history of providing more efficient oil recovery in solvent extraction. The Solvex will pay for itself through increased capacities with better residuals and decreased energy and solvent consumptions.

Contact our experts today to learn more about adding the Anderson Solvex to your operations.
(216) 641-1112 // (800) 336-4730 // andersonintl.com